



Installation Manual

Open Land System ISYS 2.2

Item - No.: FRTSTV

Thank you very much for choosing our mounting system.

With these instructions we will describe to you in detail how to proceed with the assembly.

If you have any questions, please do not hesitate to contact us at any time.

Content:

1.	General Information	3
1.1	Designation of the individual parts	3
1.2	Overview of required tools and auxiliary materials	3
1.3	Tightening torques for screws	4
2.	The Assembly	4
3.	Theft protection	13
4.	Maintenance	14
5.	Surface treatment and corrosion	14
6.	Safety and liability	15
6.1.	Electrical Installation	15
6.2.	Safety at work	15
6.3	Disclaimer	16

Dear Customer,

With the purchase of our systems you have not only secured technically mature products, but also an excellent, complete service.

Our competent employees will advise you at any time if questions arise and will deal with your request in detail and of course make sure that everything is carried out to your satisfaction.

Compared to conventional systems, our specially developed mounting systems have significant, time-saving features that enable more efficient work when mounting the substructure and modules!

If you do not want to deal with the installation yourself, simply request a quotation for the installation of your project. We work together with the best installation companies worldwide and can offer extremely economical conditions due to our many years of experience.

If you install your project yourself, we wish you success and hope that you were satisfied with our service.

Your Oberhauser Team

1. General Information

- The soil conditions for the structures should be leveled and load-bearing.
- The electrical connection may only be carried out by a qualified electrician.
- The completed photovoltaic project should be completely surrounded by a fence to protect it from unauthorized access or damage by wild animals.
- All packaging material must be disposed properly in accordance with legal and technical regulations. See EN 378.
- The mounting systems from Oberhauser serve exclusively as substructure for installing photovoltaic modules and may only be used in accordance with their structural analysis.
- The photovoltaic modules may only be installed in accordance with the manufacturer's instructions.

1.1 Designation of the individual parts

A = Ram profile C140 x 80 mm, Length according to requirements

B = Rafter profile C100 x 50 mm, Length according to requirements

C = Purlin C75 x 50 mm, Length according to requirements

D = Purlin connector

E = Hexagonal screw DIN 933 – M12 x 40, Material: A2-70 or 8.8

F = Washer DIN 9021 – 13,0 mm; Material: A2 – 70 or 8.8

G = Hexagonal nut DIN 6923 – M12; Material: A2 – 70 or 8.8

H = Module middle clamp

I = Module end clamp

1.2 Overview of required tools and auxiliary materials

Iron bars

Cordless screwdriver with torque limiter

Pencil

Inclinometer

Large angle approx. 2000 mm

Screw insert 6 mm

Ratchet with torque and socket wrench insert 19 mm

Ratchet with torque and socket wrench insert 17 mm

Measuring tape min. 50 m

Cord 50 – 100 m

1.3 Tightening torques for screws

Hexagon head screw DIN933 M12x40 (ram profile (A) - rafter profile (B))	100 Nm
Hexagon head screw DIN EN 14399/4 M12x40 (HV)	130 Nm
Hexagon head screw DIN933 M12x40 (rafter profile (B) - purlins (C))	60 Nm
Screws for module clamps	8 - 10 Nm

After assembly, a random check of the tightening torque, min. 5 % of all screw connections, is recommended. The inspection should be repeated annually as part of the maintenance work.

2. The Assembly

A proven method is the foundation by means of ram profiles consisting of galvanized steel. The static requirements at the site and the results of the soil investigation are decisive for the length of the piles.

These are rammed into the ground by pile-driving machines, whereby optimum alignment in all directions is possible.

Step 1: Measuring of the ram points and material distribution

Red marks:

These marks are measured in advance by the surveyor and permanently marked. The surveyor is commissioned by the client and should start surveying at the earliest one week before the start of construction and have completed the work by the day of the start of construction at the latest.

Black marks:

These marks are measured by the installation team. This is usually done by laying out a long measuring tape (50 - 100 m) and then marking the ram points (black marks) on the measuring tape. The distances depend on the pile-driving plan and the measuring charts which you receive from Oberhauser.

The material (piles) is then distributed in the field to make assembly times more efficient.

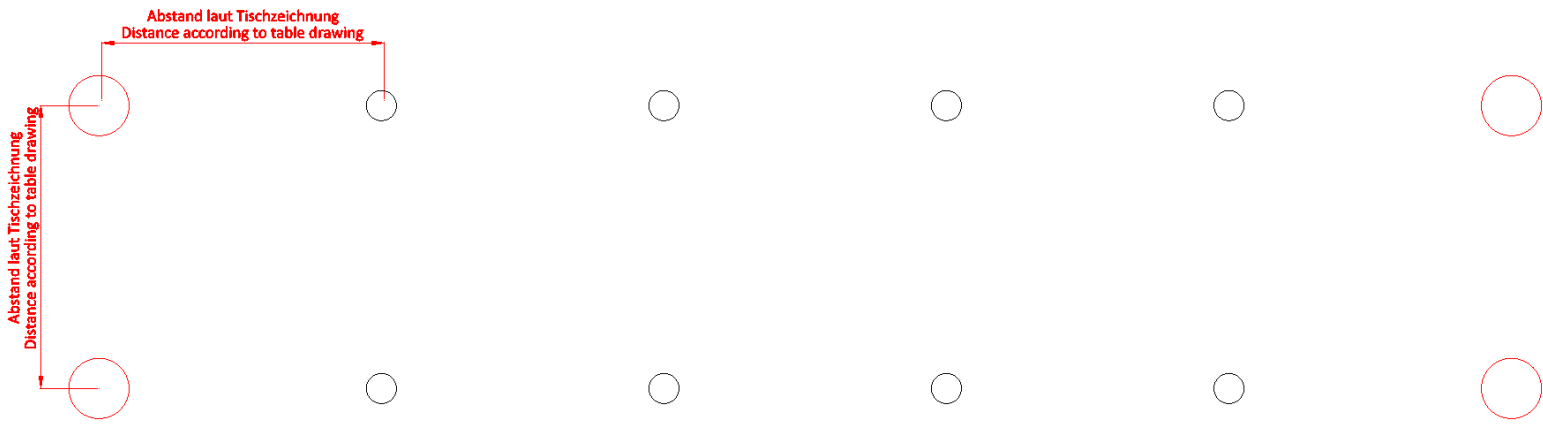

Step 2: Ramming works

1

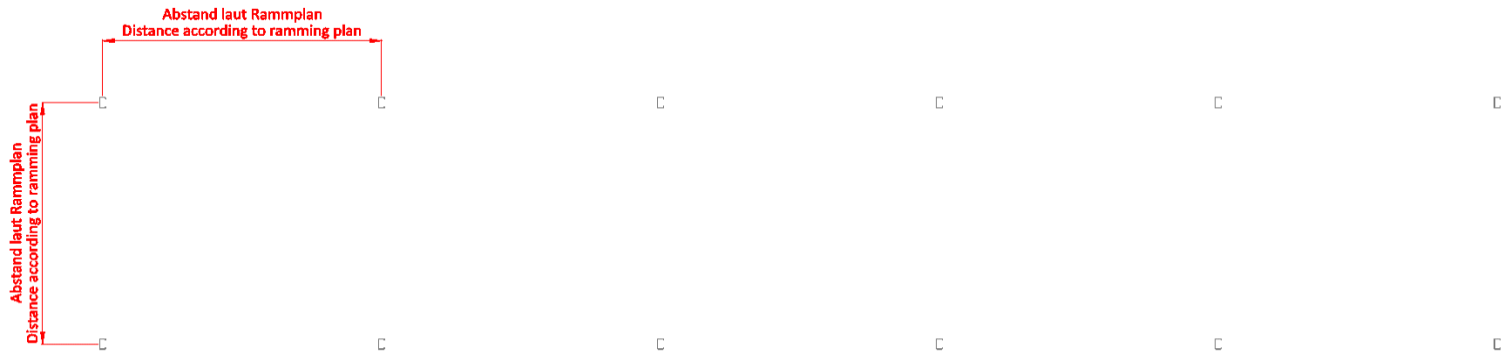

2

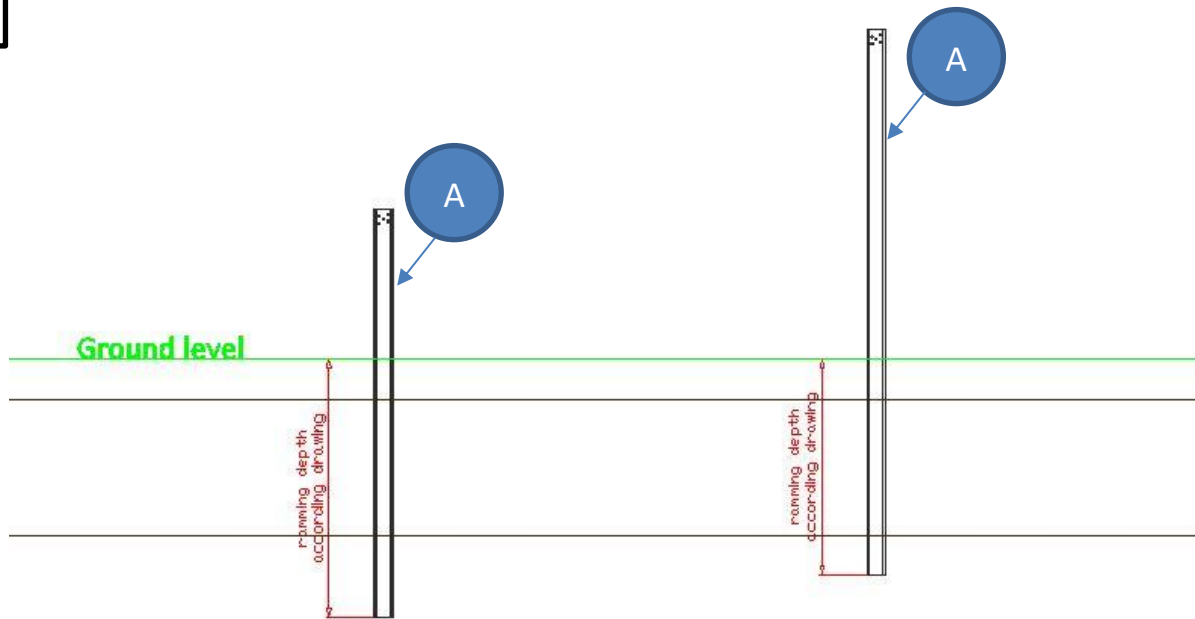

Step 3: Installation of rafter profiles

1

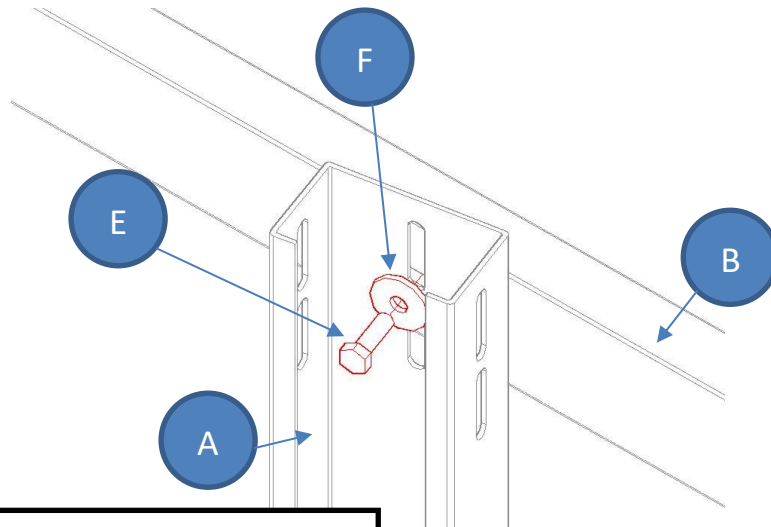

Torque: 100 Nm on the screw head (A2/A4)
130 Nm on the screw head (HV)

2

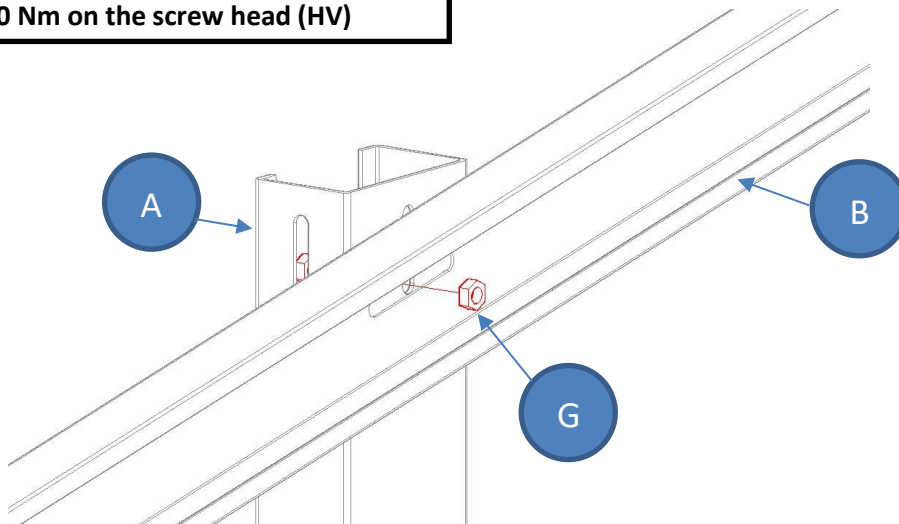

3

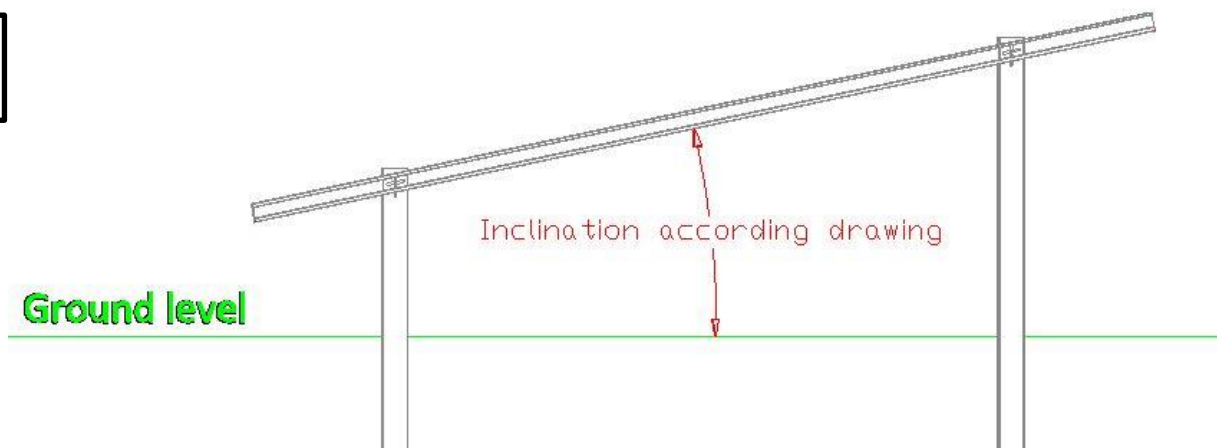

Step 4: Installation of purlins

1

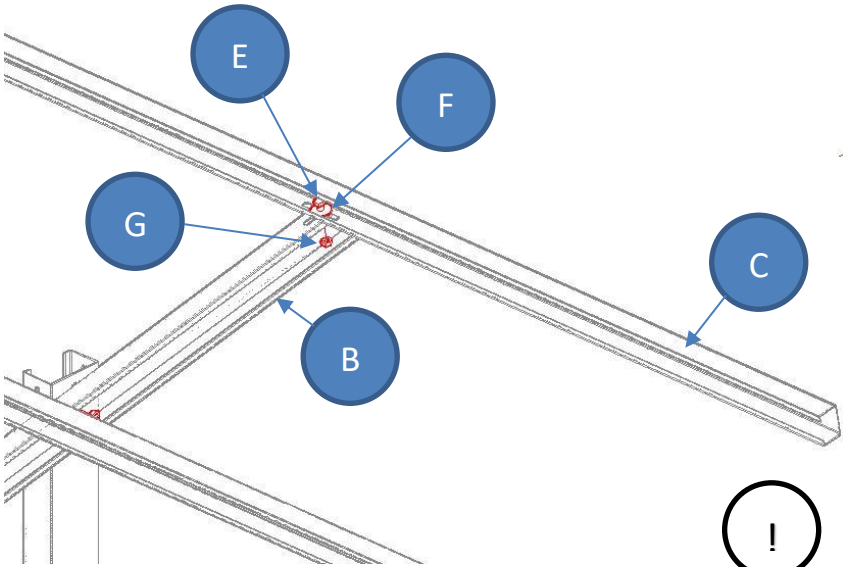

Torque: 60 Nm

2

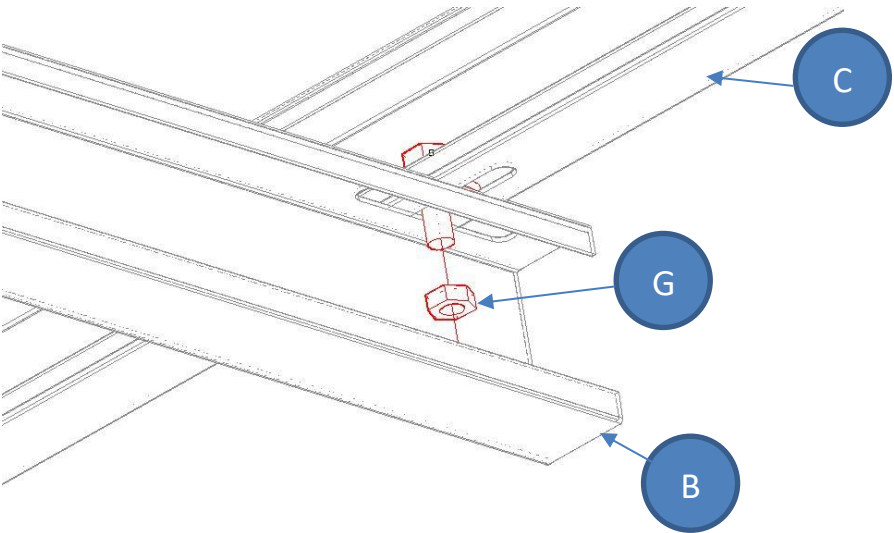

3

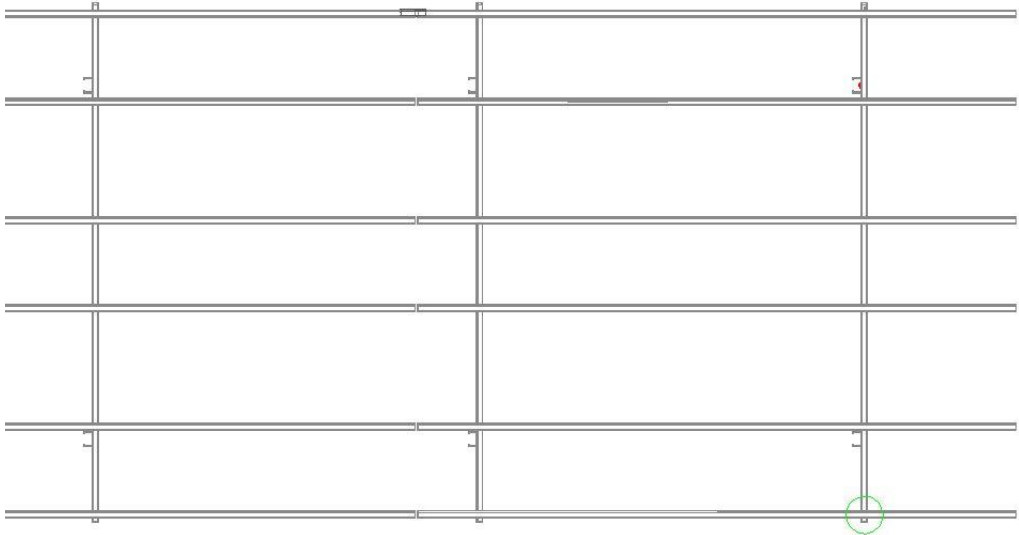

Step 5: Installation of purlin - connectors

1

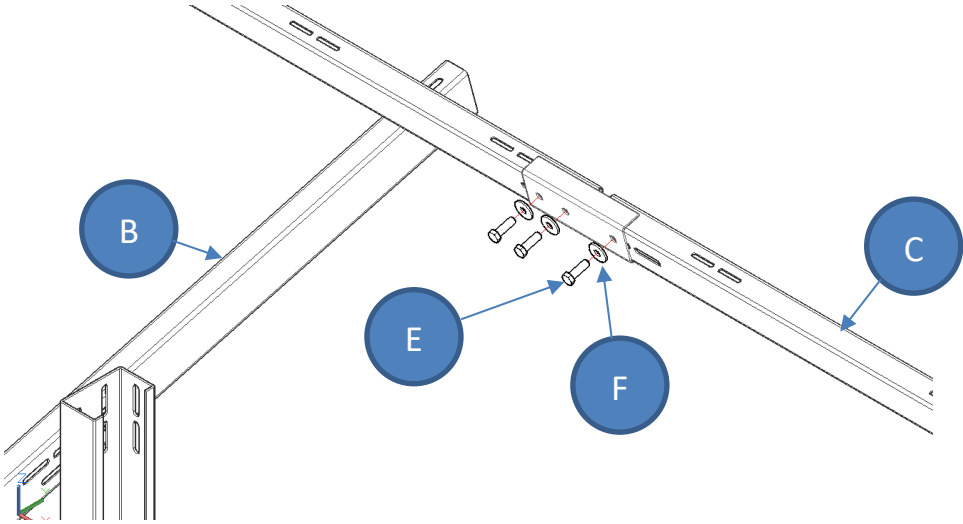

2

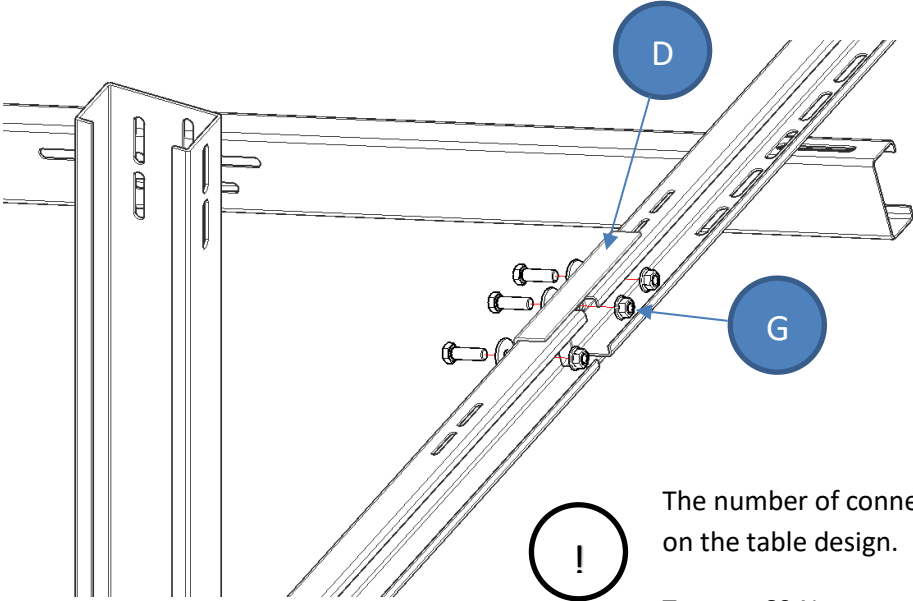

The number of connectors to be used depends on the table design.

Torque: 60 Nm

3

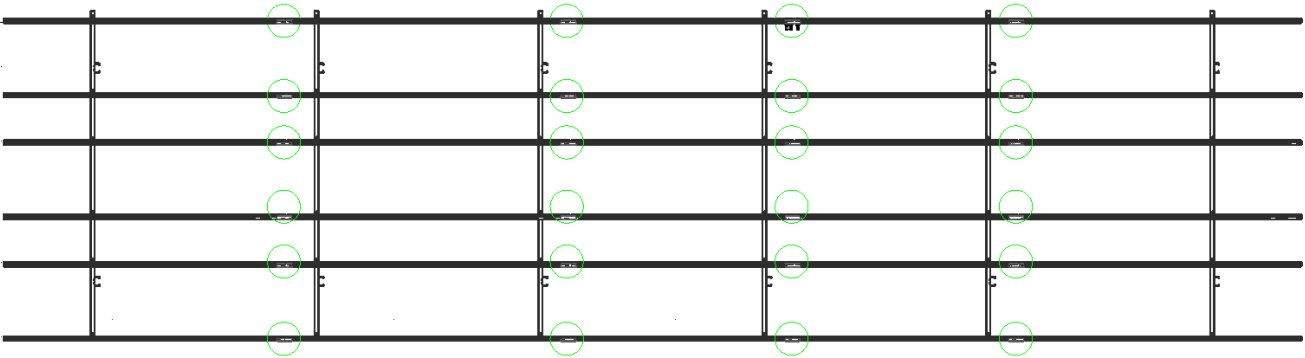

Step 6: Installation of modules

1

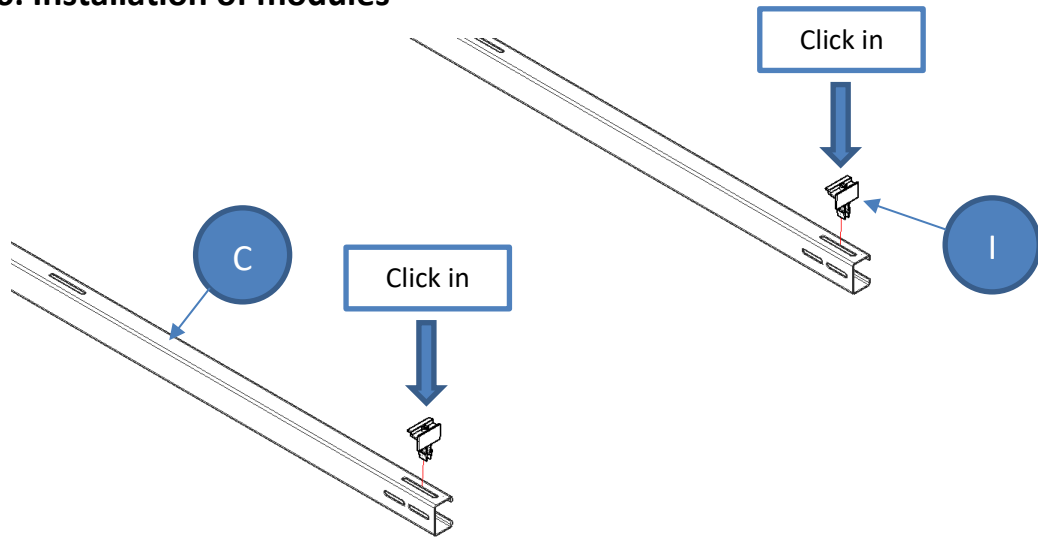

2

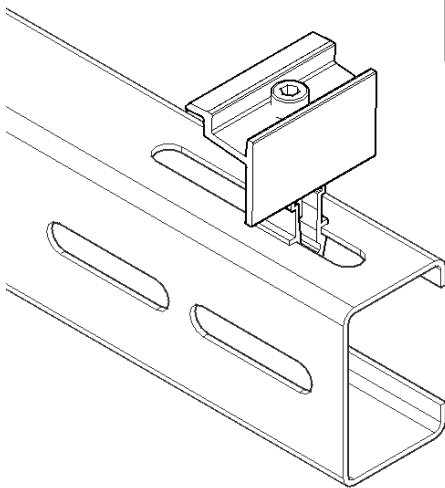

3

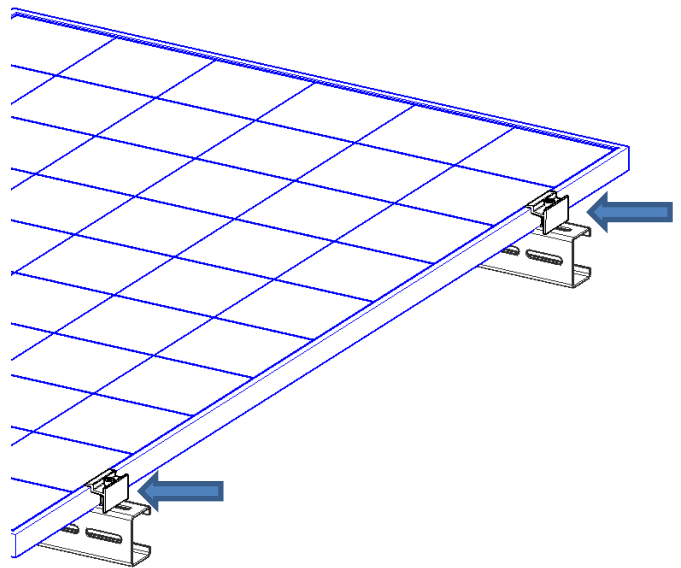

4

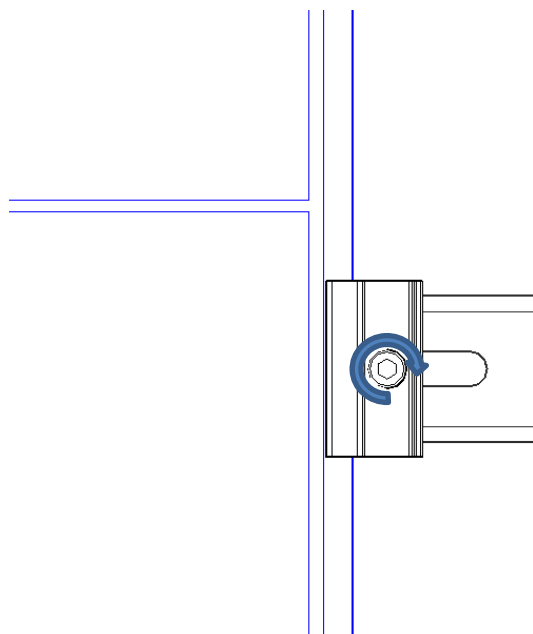

! Torque: 8 - 10 Nm

B-B

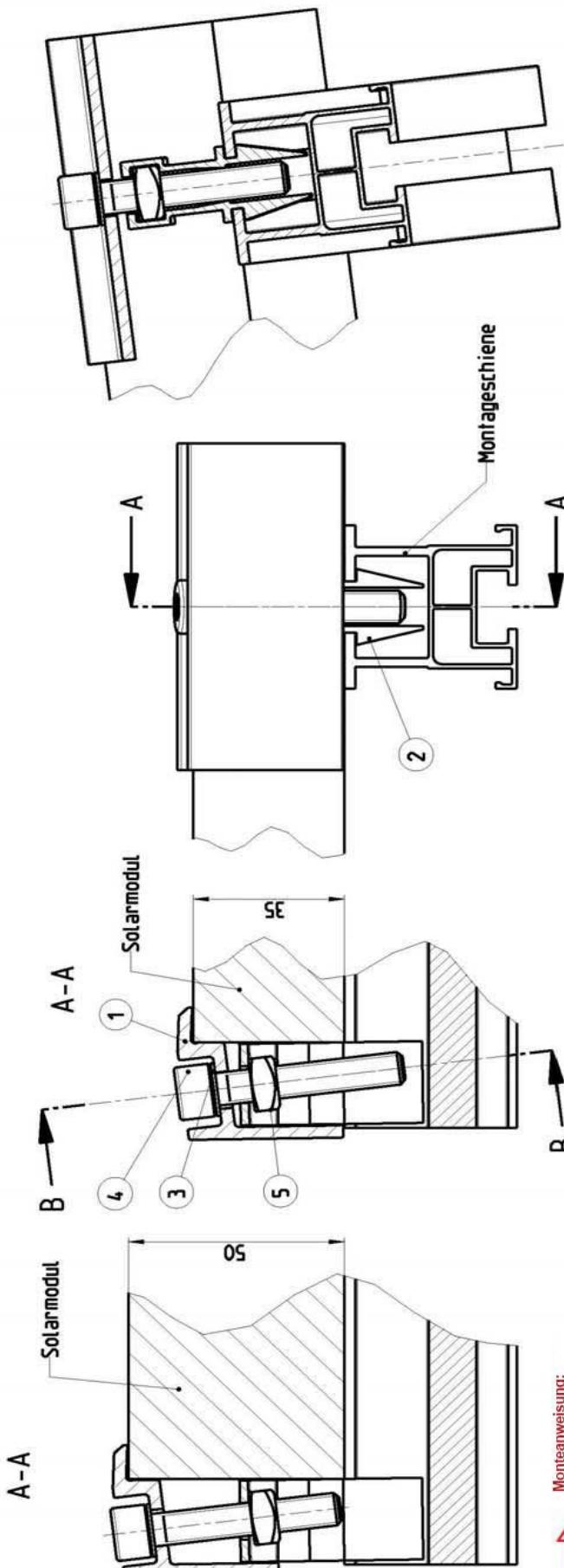

Monteanweisung:
In Pfeilrichtung fest andrücken

Installation advice:
Press towards this direction

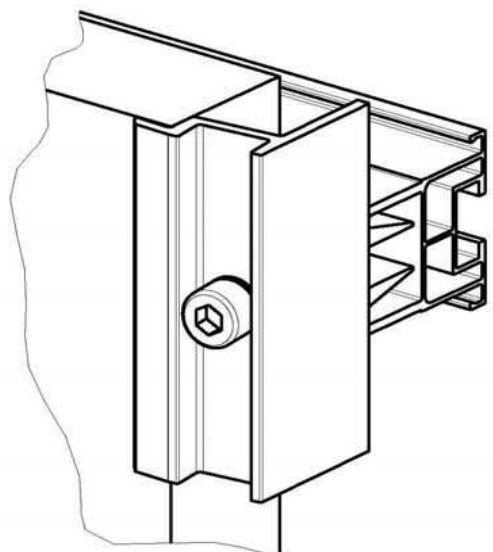
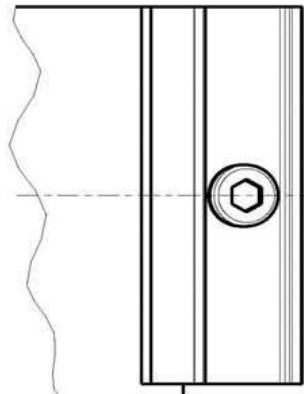

Oberflächenbehandlung	Abmessung	1:1	Maßstab	1:1	Masse
	Druck		Werkstoff/Holzzeug		
Oberflächenbehandlung	Abmessung	12.01.11	Bezeichnung	Modulklemme_kpl	
	Druck		Zeichnung/Socht-Nr.:	10.1328-00-00	
	Druck		Erst. für	Ers. durch	
	Druck				

5

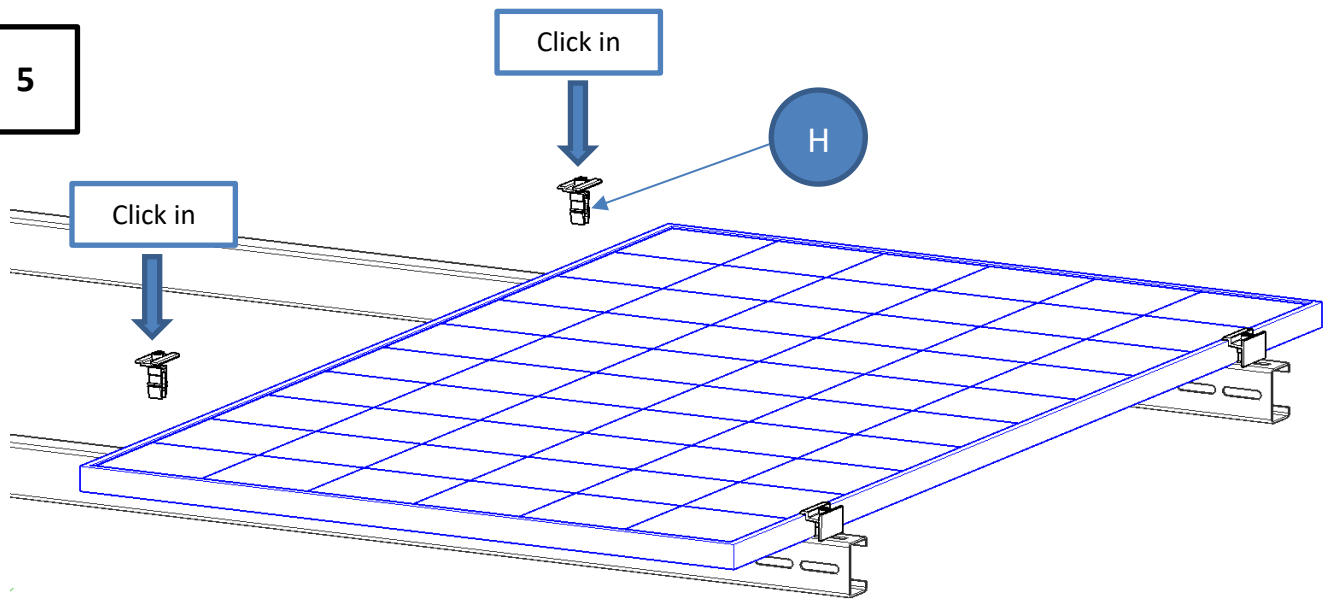

6

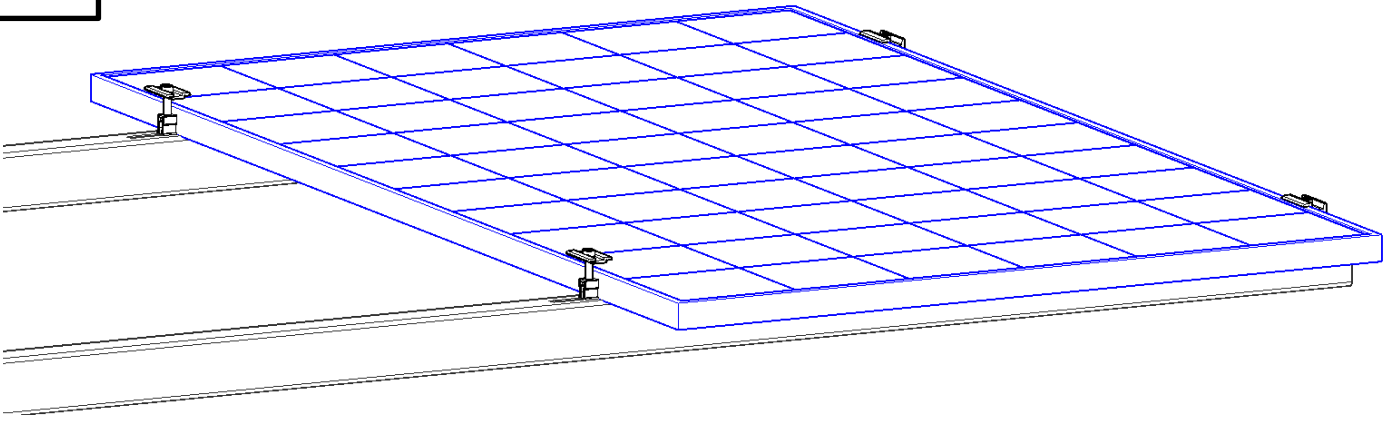

7

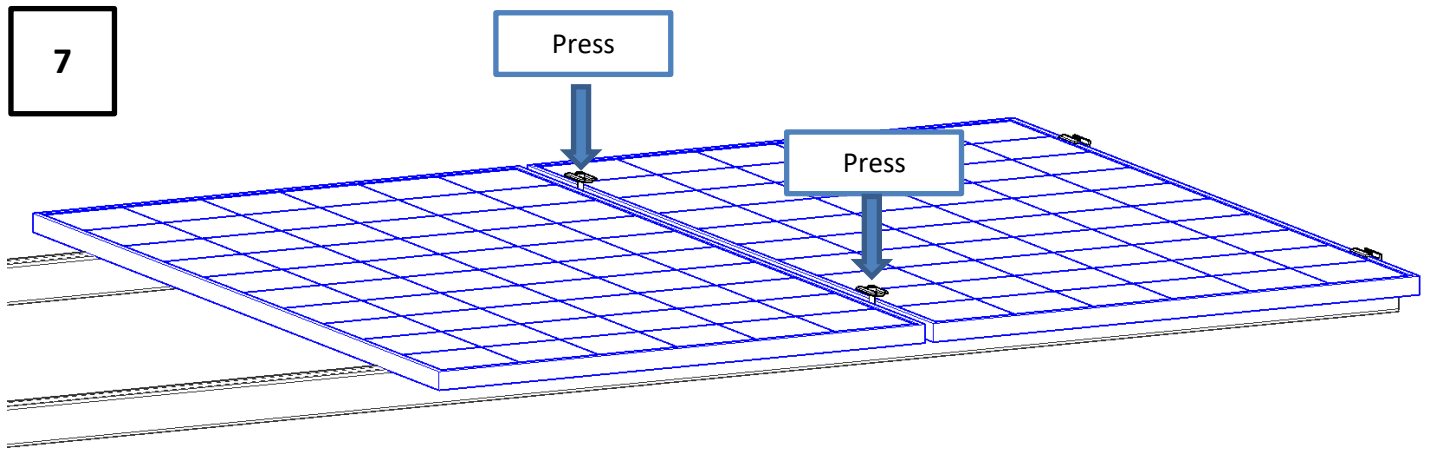

8

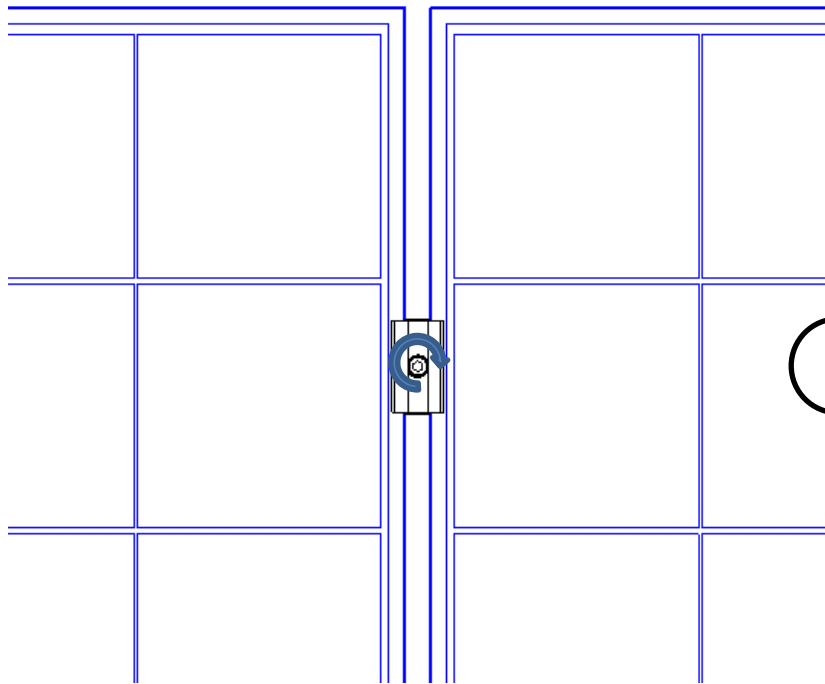

Torque: 8 - 10 Nm

9

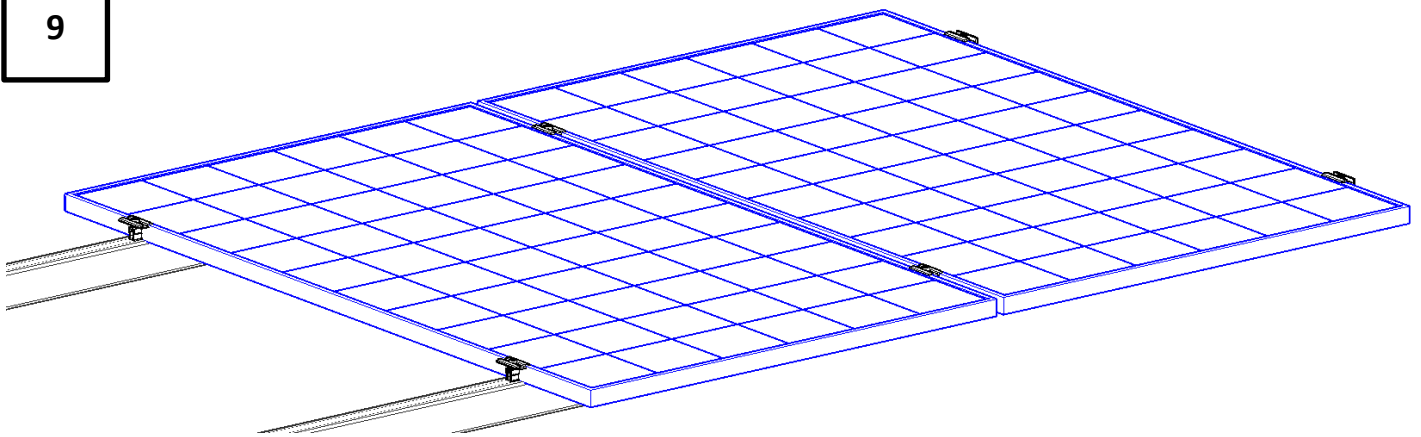

Continue until the last module in the row is fixed.
At the end of the row a module end clamp is used again.

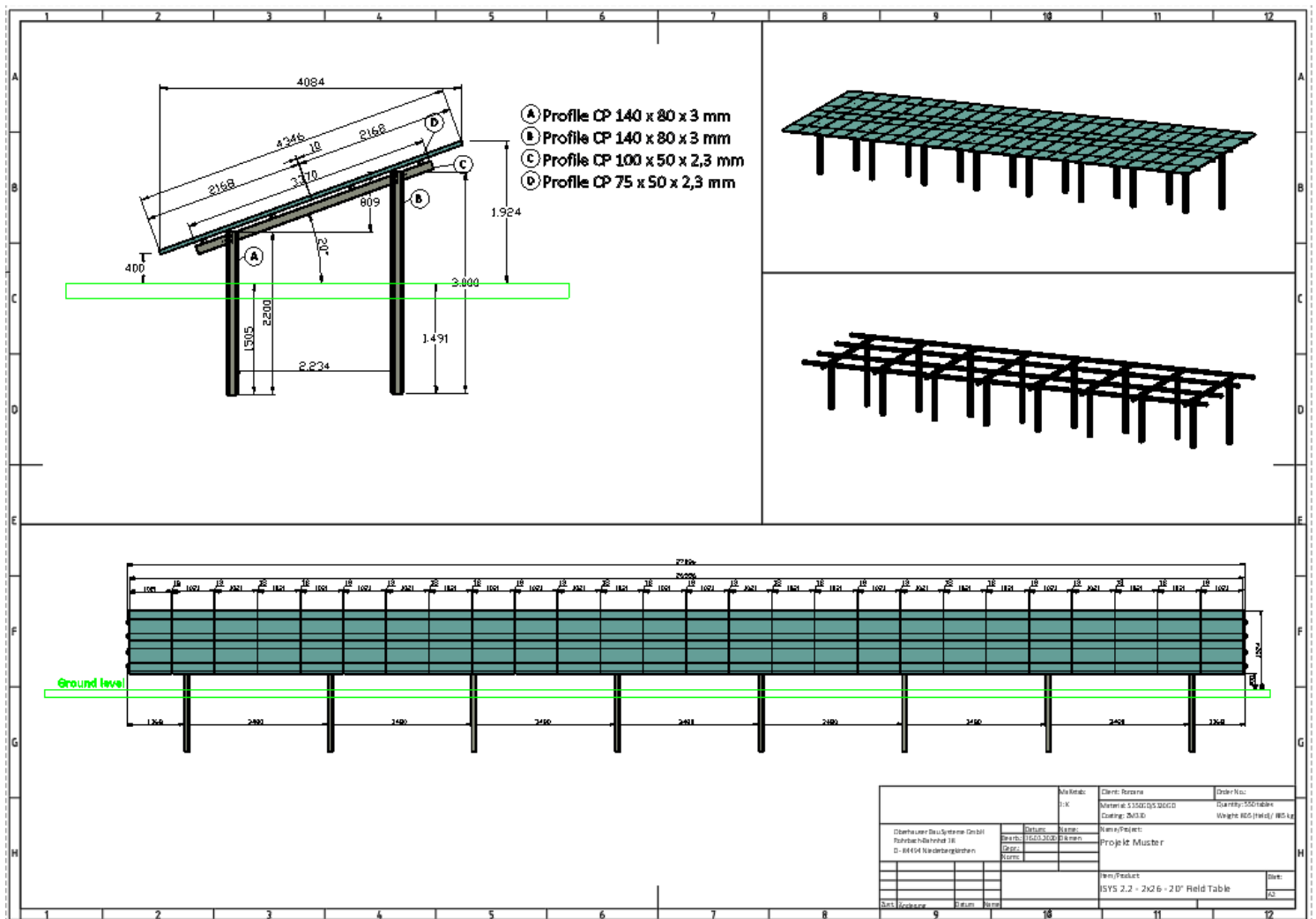

For each project you will receive an individual table drawing as well as a layout plan, a shading- and a ramming plan.

3. Theft protection

"Opportunity makes the thief!" In order to prevent this from happening, we will be pleased to supply you with our safety balls or, optionally, shear nuts and/or safety screws on request.

Depending on the measures selected, theft is made more difficult or even prevented.

However, 100% theft protection is not possible, since any system can be "cracked" with the right tools and in the required time.

4. Maintenance

Solar plants have to be maintained in regular intervals (at least once a year), to ensure an optimal functioning and to meet the warranty requirements. At least once a year a visual inspection of the profiles and fixing materials regarding damage or corrosion should be carried out and also a random inspection of the connection points (screws, nuts) should be performed.

Especially after heavy weather occurrences like storms there should be additional inspections with special emphasis on the exposed or outer areas of the project site where wind influences can cause damages.

Damaged parts of the system have to be repaired or replaced. Loose screw connections have to be tightened again using the torque information given in this manual (§1.3).

In case of polluted modules, we recommend to clean them for optimal performance. Module cleaning should be performed by professional companies following the manufacturer's instructions.

In case of major damages to the mounting system or to electrical parts, be advised to contact a professional company. We point out that there are risks to health and life performing this work.

5. Surface treatment and corrosion

Oberhauser mounting systems are made of aluminium and/or galvanized steel. Depending on the project location, the atmospheric conditions may vary.

The surface treatment also depends on the chemical characteristics of the soil. These must be provided by the client by means of appropriate expert opinions when the contract is awarded.

The company Oberhauser Bau - Systeme GmbH certifies surface lifetime of 25 years within the scope of and in accordance with all general terms and conditions of Oberhauser Bau - Systeme GmbH and the following conditions.

1. The scope of the surface guarantee is limited, at our discretion, to the assumption of the costs of repairing the defective profiles or the delivery of defect-free profiles at our expense to the customer's place of business so that the customer can replace the defective profiles himself. These must be profiles with the same or higher properties and of the same type.
2. The surface guarantee does not apply to transport damage or damage to the profiles during installation. Profiles that are driven into the ground must be re-galvanized by the customer or the appointed installation company. Post-zinc coating cannot be compared with a zinc coating produced by the factory and must therefore be checked regularly and reworked if necessary.
3. The guarantee cannot be transferred to third parties
4. The surface guarantee is valid for 25 years for installations in areas with normal atmospheric conditions with regard to corrosion (corrosion classes C1 to C3 according to EN ISO 12944-2). Systems in more aggressive environments C4 - CX must be considered separately. Additional corrosion protection is recommended in this case.
5. The surface guarantee does not apply to areas with heavily polluted air or closer than 2 km from the sea coast and/or to areas where the installations frequently come into contact with fresh or salt water.

6. The surface guarantee does not apply to installations exposed to any type of chemical that may cause corrosion, such as smoke and rainwater containing carbon, deposits or particles of heavy metals, alkaline products such as ash, cement or animal excrements, or to installations located in the vicinity of a sewage treatment plant.
7. The visual appearance of the cutting edges and the discoloration of the zinc surface due to water runoff from cutting edges or adjacent parts is not covered by the surface warranty.
8. The warranty does not apply to areas with high zinc abrasion (desert areas, areas with sandy soils and strong winds).
9. The mounting system must be inspected annually by the customer or his vicarious agent. Any damage detected must be repaired (scratches, dents, etc.) The entire system must be serviced annually in accordance with Oberhauser's assembly instructions and the assembly and maintenance instructions contained therein. The customer or his vicarious agent or his representative is responsible for this.
10. All our warranty services are subject to full payment of the purchase price by the customer. They exist within the granted period from the day of building approval, but at the latest from the day of final invoicing.
11. These conditions are a complete part of the contract concluded between Oberhauser Bau-Systeme GmbH and the customer.

6. Safety and liability

6.1 Electrical installation

Our assembly instructions do not provide any electrical installation instructions, but are exclusively dedicated to the assembly of the substructure and the modules for a PV system.

Therefore we do not assume any liability for damages caused by the electrical system.

However, you should observe the following instructions:

- Installation and commissioning should be carried out by qualified electricians.
- Observe valid regulations and safety instructions.
- Do not carry out electrical installation in damp conditions.
- Even low lighting can lead to very high DC voltages at the connection of solar modules and can therefore be life-threatening if touched!

6.2 Safety at work

The valid accident prevention regulations should be observed and followed for all types of work.

In addition, only tested power tools should be used and the danger area should be cordoned off.

In order to avoid injuries, sufficient personal protective equipment such as safety shoes, appropriate work clothing, work gloves, safety goggles, helmet, etc. must be used.

Information can also be obtained from the building trade association.

6.3 Disclaimer

This installation manual contains notes and recommendations for the installation of photovoltaic mounting systems from Oberhauser.

In addition to our instructions, the installing specialist company should observe the valid regulations and rules of technology.

Oberhauser is not liable for the dimensioning information contained in commercial investment offers.

The components made by Oberhauser are designed for the expected loads and the current state of the art.

Oberhauser is not liable for improper handling of the installed components.

With proper handling, dimensioning according to the static conditions, adherence to the maintenance instructions and (unless otherwise agreed) normal environmental conditions, Oberhauser provides a 10 - year product warranty for the durability of the mounting systems. This applies within the framework of the environmental conditions to be taken into account e.g. EC1.

Since the static dimensioning cannot be carried out for all possible environmental conditions, but only according to the valid standards, appropriate elementary insurances are recommended.

oberhauser

Bau » Systeme

Oberhauser Bau-Systeme GmbH

Rohrbach-Bahnhof 18
84494 Niederbergkirchen

Tel.: +49 (0) 8635 69392- 0

Fax: +49 (0) 8635 69392-20

E-Mail: info@oberhauser-pv.de

